

# Introducción a elementos finitos

## Segundo Parcial II-2016

1. Calcular la matriz de rigidez de la placa de espesor  $t$  sujeta a esfuerzo plano, usando un elemento en coordenadas naturales

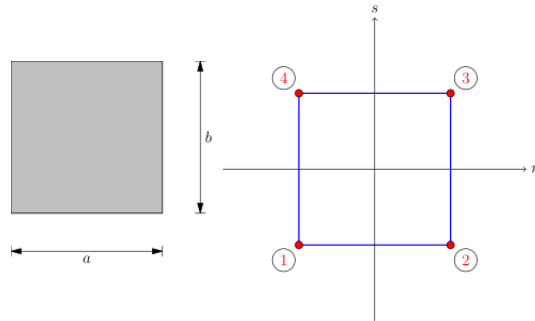

### Solución 1

La matriz de rigidez es

$$K = \int_{-1}^1 \int_{-1}^1 B^T C B \det J t ds dr$$

La matriz constitutiva es

$$C = \frac{E}{1 - \nu^2} \begin{bmatrix} 1 & \nu & 0 \\ \nu & 1 & 0 \\ 0 & 0 & \frac{1-\nu}{2} \end{bmatrix}$$

Funciones de forma unidimensional de dos nodos

$$N(r) = \left[ \frac{1}{2} - \frac{1}{2}r \quad \frac{1}{2} + \frac{1}{2}r \right]$$

$$N(s) = \left[ \frac{1}{2} - \frac{1}{2}s \quad \frac{1}{2} + \frac{1}{2}s \right]$$

Multiplicando

$$\begin{bmatrix} \frac{1}{2} - \frac{1}{2}r \\ \frac{1}{2} + \frac{1}{2}r \end{bmatrix} \begin{bmatrix} \frac{1}{2} - \frac{1}{2}s & \frac{1}{2} + \frac{1}{2}s \end{bmatrix} = \begin{bmatrix} \frac{1}{4}(r-1)(s-1) & -\frac{1}{4}(r-1)(s+1) \\ -\frac{1}{4}(r+1)(s-1) & \frac{1}{4}(r+1)(s+1) \end{bmatrix} \\ = \begin{bmatrix} N_1 & N_4 \\ N_2 & N_3 \end{bmatrix}$$

Escribiendo en la forma estándar

$$N^T = \begin{bmatrix} \frac{1}{4}(r-1)(s-1) \\ -\frac{1}{4}(r+1)(s-1) \\ \frac{1}{4}(r+1)(s+1) \\ -\frac{1}{4}(r-1)(s+1) \end{bmatrix} = \begin{bmatrix} N_1 \\ N_2 \\ N_3 \\ N_4 \end{bmatrix}$$

Colocando un sistema de referencia

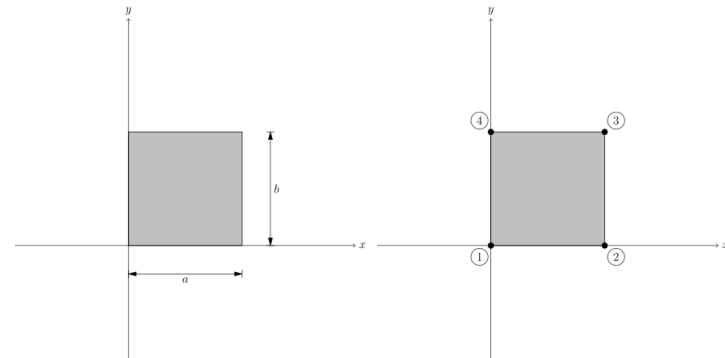

Coordenadas de los nodos

$$[x_1, y_1] = [0, 0] \quad [x_3, y_3] = [a, b]$$

$$[x_2, y_2] = [a, 0] \quad [x_4, y_4] = [0, b]$$

Funciones que interpolan la geometría

$$x = N_1 x_1 + N_2 x_2 + N_3 x_3 + N_4 x_4$$

$$y = N_1 y_1 + N_2 y_2 + N_3 y_3 + N_4 y_4$$

Reemplazando las coordenadas de los nodos

$$x = \frac{a}{2}(r+1)$$

$$y = \frac{b}{2}(s+1)$$

El jacobiano y el jacobiano inverso son

$$J = \begin{bmatrix} \frac{\partial x}{\partial r} & \frac{\partial y}{\partial r} \\ \frac{\partial x}{\partial s} & \frac{\partial y}{\partial s} \end{bmatrix} \quad J^{-1} = \begin{bmatrix} \frac{\partial r}{\partial x} & \frac{\partial s}{\partial x} \\ \frac{\partial r}{\partial y} & \frac{\partial s}{\partial y} \end{bmatrix}$$

Reemplazando derivadas

$$J = \begin{bmatrix} \frac{a}{2} & 0 \\ 0 & \frac{b}{2} \end{bmatrix} \quad J^{-1} = \begin{bmatrix} \frac{2}{a} & 0 \\ 0 & \frac{2}{b} \end{bmatrix}$$

Determinante del jacobiano

$$\det J = \frac{ab}{4}$$

La matriz de deformaciones es

$$B = \begin{bmatrix} \frac{\partial N_1}{\partial x} & 0 & \frac{\partial N_2}{\partial x} & 0 & \frac{\partial N_3}{\partial x} & 0 & \frac{\partial N_4}{\partial x} & 0 \\ 0 & \frac{\partial N_1}{\partial y} & 0 & \frac{\partial N_2}{\partial y} & 0 & \frac{\partial N_3}{\partial y} & 0 & \frac{\partial N_4}{\partial y} \\ \frac{\partial N_1}{\partial y} & \frac{\partial N_1}{\partial x} & \frac{\partial N_2}{\partial y} & \frac{\partial N_2}{\partial x} & \frac{\partial N_3}{\partial y} & \frac{\partial N_3}{\partial x} & \frac{\partial N_4}{\partial y} & \frac{\partial N_4}{\partial x} \end{bmatrix}$$

Debido a que las funciones de forma están en función de  $r$  y  $s$ , se usará la regla de la cadena

$$\frac{\partial N_i}{\partial x} = \frac{\partial N_i}{\partial r} \frac{\partial r}{\partial x} + \frac{\partial N_i}{\partial s} \frac{\partial s}{\partial x}$$

$$\frac{\partial N_i}{\partial y} = \frac{\partial N_i}{\partial r} \frac{\partial r}{\partial y} + \frac{\partial N_i}{\partial s} \frac{\partial s}{\partial y}$$

Reemplazando en  $B_i$

$$B_1 = \begin{bmatrix} \frac{\partial N_1}{\partial r} \frac{\partial r}{\partial x} + \frac{\partial N_1}{\partial s} \frac{\partial s}{\partial x} & 0 & \frac{\partial N_1}{\partial r} \frac{\partial r}{\partial y} + \frac{\partial N_1}{\partial s} \frac{\partial s}{\partial y} \\ 0 & \frac{\partial N_1}{\partial r} \frac{\partial r}{\partial x} + \frac{\partial N_1}{\partial s} \frac{\partial s}{\partial x} & \frac{\partial N_1}{\partial r} \frac{\partial r}{\partial y} + \frac{\partial N_1}{\partial s} \frac{\partial s}{\partial y} \\ \frac{\partial N_1}{\partial r} \frac{\partial r}{\partial y} + \frac{\partial N_1}{\partial s} \frac{\partial s}{\partial y} & \frac{\partial N_1}{\partial r} \frac{\partial r}{\partial x} + \frac{\partial N_1}{\partial s} \frac{\partial s}{\partial x} & \frac{\partial N_1}{\partial r} \frac{\partial r}{\partial y} + \frac{\partial N_1}{\partial s} \frac{\partial s}{\partial y} \end{bmatrix} = \begin{bmatrix} \frac{s-1}{2a} & 0 \\ 0 & \frac{r-1}{2b} \\ \frac{r-1}{2b} & \frac{s-1}{2a} \end{bmatrix}$$

$$B_2 = \begin{bmatrix} \frac{\partial N_2}{\partial r} \frac{\partial r}{\partial x} + \frac{\partial N_2}{\partial s} \frac{\partial s}{\partial x} & 0 & \frac{\partial N_2}{\partial r} \frac{\partial r}{\partial y} + \frac{\partial N_2}{\partial s} \frac{\partial s}{\partial y} \\ 0 & \frac{\partial N_2}{\partial r} \frac{\partial r}{\partial x} + \frac{\partial N_2}{\partial s} \frac{\partial s}{\partial x} & \frac{\partial N_2}{\partial r} \frac{\partial r}{\partial y} + \frac{\partial N_2}{\partial s} \frac{\partial s}{\partial y} \\ \frac{\partial N_2}{\partial r} \frac{\partial r}{\partial y} + \frac{\partial N_2}{\partial s} \frac{\partial s}{\partial y} & \frac{\partial N_2}{\partial r} \frac{\partial r}{\partial x} + \frac{\partial N_2}{\partial s} \frac{\partial s}{\partial x} & \frac{\partial N_2}{\partial r} \frac{\partial r}{\partial y} + \frac{\partial N_2}{\partial s} \frac{\partial s}{\partial y} \end{bmatrix} = \begin{bmatrix} -\frac{s-1}{2a} & 0 \\ 0 & -\frac{r+1}{2b} \\ -\frac{r+1}{2b} & -\frac{s-1}{2a} \end{bmatrix}$$

$$B_3 = \begin{bmatrix} \frac{\partial N_3}{\partial r} \frac{\partial r}{\partial x} + \frac{\partial N_3}{\partial s} \frac{\partial s}{\partial x} & 0 & \frac{\partial N_3}{\partial r} \frac{\partial r}{\partial y} + \frac{\partial N_3}{\partial s} \frac{\partial s}{\partial y} \\ 0 & \frac{\partial N_3}{\partial r} \frac{\partial r}{\partial x} + \frac{\partial N_3}{\partial s} \frac{\partial s}{\partial x} & \frac{\partial N_3}{\partial r} \frac{\partial r}{\partial y} + \frac{\partial N_3}{\partial s} \frac{\partial s}{\partial y} \\ \frac{\partial N_3}{\partial r} \frac{\partial r}{\partial y} + \frac{\partial N_3}{\partial s} \frac{\partial s}{\partial y} & \frac{\partial N_3}{\partial r} \frac{\partial r}{\partial x} + \frac{\partial N_3}{\partial s} \frac{\partial s}{\partial x} & \frac{\partial N_3}{\partial r} \frac{\partial r}{\partial y} + \frac{\partial N_3}{\partial s} \frac{\partial s}{\partial y} \end{bmatrix} = \begin{bmatrix} \frac{s+1}{2a} & 0 \\ 0 & \frac{r+1}{2b} \\ \frac{r+1}{2b} & \frac{s+1}{2a} \end{bmatrix}$$

$$B_4 = \begin{bmatrix} \frac{\partial N_4}{\partial r} \frac{\partial r}{\partial x} + \frac{\partial N_4}{\partial s} \frac{\partial s}{\partial x} & 0 & \frac{\partial N_4}{\partial r} \frac{\partial r}{\partial y} + \frac{\partial N_4}{\partial s} \frac{\partial s}{\partial y} \\ 0 & \frac{\partial N_4}{\partial r} \frac{\partial r}{\partial x} + \frac{\partial N_4}{\partial s} \frac{\partial s}{\partial x} & \frac{\partial N_4}{\partial r} \frac{\partial r}{\partial y} + \frac{\partial N_4}{\partial s} \frac{\partial s}{\partial y} \\ \frac{\partial N_4}{\partial r} \frac{\partial r}{\partial y} + \frac{\partial N_4}{\partial s} \frac{\partial s}{\partial y} & \frac{\partial N_4}{\partial r} \frac{\partial r}{\partial x} + \frac{\partial N_4}{\partial s} \frac{\partial s}{\partial x} & \frac{\partial N_4}{\partial r} \frac{\partial r}{\partial y} + \frac{\partial N_4}{\partial s} \frac{\partial s}{\partial y} \end{bmatrix} = \begin{bmatrix} -\frac{s+1}{2a} & 0 \\ 0 & -\frac{r-1}{2b} \\ -\frac{r-1}{2b} & -\frac{s+1}{2a} \end{bmatrix}$$

Reemplazando en  $B$

$$B = \begin{bmatrix} \frac{s-1}{2a} & 0 & -\frac{s-1}{2a} & 0 & \frac{s+1}{2a} & 0 & -\frac{s+1}{2a} & 0 \\ 0 & \frac{r-1}{2b} & 0 & -\frac{r+1}{2b} & 0 & \frac{r+1}{2b} & 0 & -\frac{r-1}{2b} \\ \frac{r-1}{2b} & \frac{s-1}{2a} & -\frac{r+1}{2b} & -\frac{s-1}{2a} & \frac{r+1}{2b} & \frac{s+1}{2a} & -\frac{r-1}{2b} & -\frac{s+1}{2a} \end{bmatrix}$$

Después de multiplicar e integrar la matriz de rigidez es de  $8 \times 8$

## Solución 2

La solución es exactamente igual hasta la matriz de deformaciones.

La matriz de deformaciones es

$$B = \begin{bmatrix} \frac{\partial N_1}{\partial x} & 0 & \frac{\partial N_2}{\partial x} & 0 & \frac{\partial N_3}{\partial x} & 0 & \frac{\partial N_4}{\partial x} & 0 \\ 0 & \frac{\partial N_1}{\partial y} & 0 & \frac{\partial N_2}{\partial y} & 0 & \frac{\partial N_3}{\partial y} & 0 & \frac{\partial N_4}{\partial y} \\ \frac{\partial N_1}{\partial y} & \frac{\partial N_1}{\partial x} & \frac{\partial N_2}{\partial y} & \frac{\partial N_2}{\partial x} & \frac{\partial N_3}{\partial y} & \frac{\partial N_3}{\partial x} & \frac{\partial N_4}{\partial y} & \frac{\partial N_4}{\partial x} \end{bmatrix}$$

Las derivadas de las funciones de forma se calcularán en forma matricial

$$\begin{bmatrix} \frac{\partial N_i}{\partial x} \\ \frac{\partial N_i}{\partial y} \end{bmatrix} = J^{-1} \begin{bmatrix} \frac{\partial N_i}{\partial r} \\ \frac{\partial N_i}{\partial s} \end{bmatrix} = \begin{bmatrix} \frac{\partial r}{\partial x} & \frac{\partial s}{\partial x} \\ \frac{\partial r}{\partial y} & \frac{\partial s}{\partial y} \end{bmatrix} \begin{bmatrix} \frac{\partial N_i}{\partial r} \\ \frac{\partial N_i}{\partial s} \end{bmatrix}$$

Reemplazando en  $N_i$

$$\begin{bmatrix} \frac{\partial N_1}{\partial x} \\ \frac{\partial N_1}{\partial y} \end{bmatrix} = \begin{bmatrix} \frac{\partial r}{\partial x} & \frac{\partial s}{\partial x} \\ \frac{\partial r}{\partial y} & \frac{\partial s}{\partial y} \end{bmatrix} \begin{bmatrix} \frac{\partial N_1}{\partial r} \\ \frac{\partial N_1}{\partial s} \end{bmatrix} = \begin{bmatrix} \frac{2}{a} & 0 \\ 0 & \frac{2}{b} \end{bmatrix} \begin{bmatrix} \frac{s-1}{4} \\ \frac{r-1}{4} \end{bmatrix} = \begin{bmatrix} \frac{s-1}{2a} \\ \frac{r-1}{2b} \end{bmatrix}$$

$$\begin{aligned} \begin{bmatrix} \frac{\partial N_2}{\partial x} \\ \frac{\partial N_2}{\partial y} \end{bmatrix} &= \begin{bmatrix} \frac{\partial r}{\partial x} & \frac{\partial s}{\partial x} \\ \frac{\partial r}{\partial y} & \frac{\partial s}{\partial y} \end{bmatrix} \begin{bmatrix} \frac{\partial N_2}{\partial r} \\ \frac{\partial N_2}{\partial s} \end{bmatrix} = \begin{bmatrix} \frac{2}{a} & 0 \\ 0 & \frac{2}{b} \end{bmatrix} \begin{bmatrix} -\frac{s-1}{4} \\ -\frac{r+1}{4} \end{bmatrix} = \begin{bmatrix} -\frac{s-1}{2a} \\ -\frac{r+1}{2b} \end{bmatrix} \\ \begin{bmatrix} \frac{\partial N_3}{\partial x} \\ \frac{\partial N_3}{\partial y} \end{bmatrix} &= \begin{bmatrix} \frac{\partial r}{\partial x} & \frac{\partial s}{\partial x} \\ \frac{\partial r}{\partial y} & \frac{\partial s}{\partial y} \end{bmatrix} \begin{bmatrix} \frac{\partial N_3}{\partial r} \\ \frac{\partial N_3}{\partial s} \end{bmatrix} = \begin{bmatrix} \frac{2}{a} & 0 \\ 0 & \frac{2}{b} \end{bmatrix} \begin{bmatrix} \frac{s+1}{4} \\ \frac{r+1}{4} \end{bmatrix} = \begin{bmatrix} \frac{s+1}{2a} \\ \frac{r+1}{2b} \end{bmatrix} \\ \begin{bmatrix} \frac{\partial N_4}{\partial x} \\ \frac{\partial N_4}{\partial y} \end{bmatrix} &= \begin{bmatrix} \frac{\partial r}{\partial x} & \frac{\partial s}{\partial x} \\ \frac{\partial r}{\partial y} & \frac{\partial s}{\partial y} \end{bmatrix} \begin{bmatrix} \frac{\partial N_4}{\partial r} \\ \frac{\partial N_4}{\partial s} \end{bmatrix} = \begin{bmatrix} \frac{2}{a} & 0 \\ 0 & \frac{2}{b} \end{bmatrix} \begin{bmatrix} -\frac{s+1}{4} \\ -\frac{r-1}{4} \end{bmatrix} = \begin{bmatrix} -\frac{s+1}{2a} \\ -\frac{r-1}{2b} \end{bmatrix} \end{aligned}$$

Reemplazando en  $B$

$$B = \begin{bmatrix} \frac{s-1}{2a} & 0 & -\frac{s-1}{2a} & 0 & \frac{s+1}{2a} & 0 & -\frac{s+1}{2a} & 0 \\ 0 & \frac{r-1}{2b} & 0 & -\frac{r+1}{2b} & 0 & \frac{r+1}{2b} & 0 & -\frac{r-1}{2b} \\ \frac{r-1}{2b} & \frac{s-1}{2a} & -\frac{r+1}{2b} & -\frac{s-1}{2a} & \frac{r+1}{2b} & \frac{s+1}{2a} & -\frac{r-1}{2b} & -\frac{s+1}{2a} \end{bmatrix}$$

Después de multiplicar e integrar la matriz de rigidez es de  $8 \times 8$

### Solución 3

La solución es exactamente igual hasta la matriz de deformaciones.

La matriz de deformaciones es

$$B = \begin{bmatrix} \frac{\partial N_1}{\partial x} & 0 & \frac{\partial N_2}{\partial x} & 0 & \frac{\partial N_3}{\partial x} & 0 & \frac{\partial N_4}{\partial x} & 0 \\ 0 & \frac{\partial N_1}{\partial y} & 0 & \frac{\partial N_2}{\partial y} & 0 & \frac{\partial N_3}{\partial y} & 0 & \frac{\partial N_4}{\partial y} \\ \frac{\partial N_1}{\partial y} & \frac{\partial N_1}{\partial x} & \frac{\partial N_2}{\partial y} & \frac{\partial N_2}{\partial x} & \frac{\partial N_3}{\partial y} & \frac{\partial N_3}{\partial x} & \frac{\partial N_4}{\partial y} & \frac{\partial N_4}{\partial x} \end{bmatrix}$$

Las derivadas de las funciones de forma se calcularán usando una forma alternativa del jacobiano inverso

$$\begin{bmatrix} \frac{\partial N_i}{\partial x} \\ \frac{\partial N_i}{\partial y} \end{bmatrix} = \frac{1}{\det J} \begin{bmatrix} J_{22} & -J_{12} \\ -J_{21} & J_{11} \end{bmatrix} \begin{bmatrix} \frac{\partial N_i}{\partial r} \\ \frac{\partial N_i}{\partial s} \end{bmatrix} = \frac{1}{\det J} \begin{bmatrix} \frac{\partial y}{\partial s} & -\frac{\partial y}{\partial r} \\ -\frac{\partial x}{\partial s} & \frac{\partial x}{\partial r} \end{bmatrix} \begin{bmatrix} \frac{\partial N_i}{\partial r} \\ \frac{\partial N_i}{\partial s} \end{bmatrix}$$

Reemplazando en  $N_i$

$$\begin{bmatrix} \frac{\partial N_1}{\partial x} \\ \frac{\partial N_1}{\partial y} \end{bmatrix} = \frac{1}{\det J} \begin{bmatrix} \frac{\partial y}{\partial s} & -\frac{\partial y}{\partial r} \\ -\frac{\partial x}{\partial s} & \frac{\partial x}{\partial r} \end{bmatrix} \begin{bmatrix} \frac{\partial N_1}{\partial r} \\ \frac{\partial N_1}{\partial s} \end{bmatrix} = \frac{1}{\frac{ab}{4}} \begin{bmatrix} \frac{b}{2} & 0 \\ 0 & \frac{a}{2} \end{bmatrix} \begin{bmatrix} \frac{s-1}{4} \\ \frac{r-1}{4} \end{bmatrix} = \begin{bmatrix} -\frac{s-1}{2a} \\ -\frac{r-1}{2b} \end{bmatrix}$$

$$\begin{aligned} \begin{bmatrix} \frac{\partial N_2}{\partial x} \\ \frac{\partial N_2}{\partial y} \end{bmatrix} &= \frac{1}{\det J} \begin{bmatrix} \frac{\partial y}{\partial s} & -\frac{\partial y}{\partial r} \\ -\frac{\partial x}{\partial s} & \frac{\partial x}{\partial r} \end{bmatrix} \begin{bmatrix} \frac{\partial N_2}{\partial r} \\ \frac{\partial N_2}{\partial s} \end{bmatrix} = \frac{1}{\frac{ab}{4}} \begin{bmatrix} \frac{b}{2} & 0 \\ 0 & \frac{a}{2} \end{bmatrix} \begin{bmatrix} -\frac{s-1}{4} \\ -\frac{r+1}{4} \end{bmatrix} = \begin{bmatrix} -\frac{s-1}{2a} \\ -\frac{r+1}{2b} \end{bmatrix} \\ \begin{bmatrix} \frac{\partial N_3}{\partial x} \\ \frac{\partial N_3}{\partial y} \end{bmatrix} &= \frac{1}{\det J} \begin{bmatrix} \frac{\partial y}{\partial s} & -\frac{\partial y}{\partial r} \\ -\frac{\partial x}{\partial s} & \frac{\partial x}{\partial r} \end{bmatrix} \begin{bmatrix} \frac{\partial N_3}{\partial r} \\ \frac{\partial N_3}{\partial s} \end{bmatrix} = \frac{1}{\frac{ab}{4}} \begin{bmatrix} \frac{b}{2} & 0 \\ 0 & \frac{a}{2} \end{bmatrix} \begin{bmatrix} \frac{s+1}{4} \\ \frac{r+1}{4} \end{bmatrix} = \begin{bmatrix} \frac{s+1}{2a} \\ \frac{r+1}{2b} \end{bmatrix} \\ \begin{bmatrix} \frac{\partial N_4}{\partial x} \\ \frac{\partial N_4}{\partial y} \end{bmatrix} &= \frac{1}{\det J} \begin{bmatrix} \frac{\partial y}{\partial s} & -\frac{\partial y}{\partial r} \\ -\frac{\partial x}{\partial s} & \frac{\partial x}{\partial r} \end{bmatrix} \begin{bmatrix} \frac{\partial N_4}{\partial r} \\ \frac{\partial N_4}{\partial s} \end{bmatrix} = \frac{1}{\frac{ab}{4}} \begin{bmatrix} \frac{b}{2} & 0 \\ 0 & \frac{a}{2} \end{bmatrix} \begin{bmatrix} -\frac{s+1}{4} \\ -\frac{r-1}{4} \end{bmatrix} = \begin{bmatrix} -\frac{s+1}{2a} \\ -\frac{r-1}{2b} \end{bmatrix} \end{aligned}$$

Reemplazando en  $B$

$$B = \begin{bmatrix} \frac{s-1}{2a} & 0 & -\frac{s-1}{2a} & 0 & \frac{s+1}{2a} & 0 & -\frac{s+1}{2a} & 0 \\ 0 & \frac{r-1}{2b} & 0 & -\frac{r+1}{2b} & 0 & \frac{r+1}{2b} & 0 & -\frac{r-1}{2b} \\ \frac{r-1}{2b} & \frac{s-1}{2a} & -\frac{r+1}{2b} & -\frac{s-1}{2a} & \frac{r+1}{2b} & \frac{s+1}{2a} & -\frac{r-1}{2b} & -\frac{s+1}{2a} \end{bmatrix}$$

Después de multiplicar e integrar la matriz de rigidez es de  $8 \times 8$

### Solución 4

La solución es exactamente igual hasta la matriz de deformaciones.

La matriz de deformaciones es

$$B = M_1 M_2 M_3$$

$$M_1 = \begin{bmatrix} 1 & 0 & 0 & 0 \\ 0 & 0 & 0 & 1 \\ 0 & 1 & 1 & 0 \end{bmatrix}$$

$$M_2 = \begin{bmatrix} \frac{\partial r}{\partial x} & \frac{\partial s}{\partial x} & 0 & 0 \\ \frac{\partial r}{\partial y} & \frac{\partial s}{\partial y} & 0 & 0 \\ 0 & 0 & \frac{\partial r}{\partial x} & \frac{\partial s}{\partial x} \\ 0 & 0 & \frac{\partial r}{\partial y} & \frac{\partial s}{\partial y} \end{bmatrix}$$

$$M_3 = \begin{bmatrix} \frac{\partial N_1}{\partial r} & 0 & \frac{\partial N_2}{\partial r} & 0 & \frac{\partial N_3}{\partial r} & 0 & \frac{\partial N_4}{\partial r} & 0 \\ \frac{\partial N_1}{\partial s} & 0 & \frac{\partial N_2}{\partial s} & 0 & \frac{\partial N_3}{\partial s} & 0 & \frac{\partial N_4}{\partial s} & 0 \\ 0 & \frac{\partial N_1}{\partial r} & 0 & \frac{\partial N_2}{\partial r} & 0 & \frac{\partial N_3}{\partial r} & 0 & \frac{\partial N_4}{\partial r} \\ 0 & \frac{\partial N_1}{\partial s} & 0 & \frac{\partial N_2}{\partial s} & 0 & \frac{\partial N_3}{\partial s} & 0 & \frac{\partial N_4}{\partial s} \end{bmatrix}$$

Reemplazando en  $M_2$  y  $M_3$

$$M_2 = \begin{bmatrix} \frac{2}{a} & 0 & 0 & 0 \\ 0 & \frac{2}{b} & 0 & 0 \\ 0 & 0 & \frac{2}{a} & 0 \\ 0 & 0 & 0 & \frac{2}{b} \end{bmatrix}$$

$$M_3 = \begin{bmatrix} \frac{s-1}{4} & 0 & -\frac{s-1}{4} & 0 & \frac{s+1}{4} & 0 & -\frac{s+1}{4} & 0 \\ \frac{r-1}{4} & 0 & -\frac{r-1}{4} & 0 & \frac{r+1}{4} & 0 & -\frac{r+1}{4} & 0 \\ 0 & \frac{s-1}{4} & 0 & -\frac{s-1}{4} & 0 & \frac{s+1}{4} & 0 & -\frac{s+1}{4} \\ 0 & \frac{r-1}{4} & 0 & -\frac{r-1}{4} & 0 & \frac{r+1}{4} & 0 & -\frac{r+1}{4} \end{bmatrix}$$

Reemplazando en  $B$

$$B = \begin{bmatrix} \frac{s-1}{2a} & 0 & -\frac{s-1}{2a} & 0 & \frac{s+1}{2a} & 0 & -\frac{s+1}{2a} & 0 \\ 0 & \frac{r-1}{2b} & 0 & -\frac{r-1}{2b} & 0 & \frac{r+1}{2b} & 0 & -\frac{r+1}{2b} \\ \frac{r-1}{2b} & \frac{s-1}{2a} & -\frac{r+1}{2b} & -\frac{s-1}{2a} & \frac{r+1}{2b} & \frac{s+1}{2a} & -\frac{r-1}{2b} & -\frac{s+1}{2a} \end{bmatrix}$$

Después de multiplicar e integrar la matriz de rigidez es de  $8 \times 8$

- Obtener la expresión de la matriz de rigidez con  $E$ ,  $I$ ,  $A$  constantes por el método de Galerkin

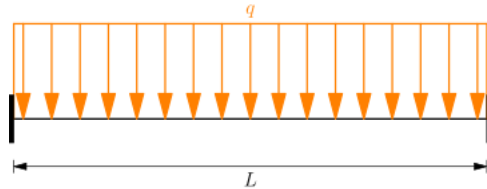

### Solución

Ecuación diferencial de la viga

$$EI \frac{d^4 v}{dx^4} + q(x) = 0$$

La aproximación de los desplazamientos será

$$v(x) = \phi(x)$$

La función ponderada será

$$W = \phi_i(x)$$

Aplicando el método de Galerkin

$$\int_0^L \left( EI \frac{d^4 \phi}{dx^4} + q \right) \phi_i dx = \int_0^L \phi_i EI \frac{d^4 \phi}{dx^4} dx + \int_0^L \phi_i q dx = 0$$

Usando el teorema de Gauss o integrando por partes

$$\left( \phi_i EI \frac{d^3 \phi}{dx^3} - \frac{d\phi_i}{dx} EI \frac{d^2 \phi}{dx^2} \right) \Big|_0^L + \int_0^L \frac{d^2 \phi_i}{dx^2} EI \frac{d^2 \phi}{dx^2} dx + \int_0^L \phi_i q dx = 0$$

Cortante y momento

$$V = EI \frac{d^3 \phi}{dx^3}$$

$$M = EI \frac{d^2 \phi}{dx^2}$$

Reemplazando

$$\left( \phi_i V - \frac{d\phi_i}{dx} M \right) \Big|_0^L + EI \int_0^L \frac{d^2 \phi_i}{dx^2} \frac{d^2 \phi}{dx^2} dx + \int_0^L \phi_i q dx = 0$$

Reordenando

$$EI \int_0^L \frac{d^2 \phi_i}{dx^2} \frac{d^2 \phi}{dx^2} dx = - \int_0^L \phi_i q dx - \left( \phi_i V - \frac{d\phi_i}{dx} M \right) \Big|_0^L$$

La matriz de rigidez es

$$K = EI \int_0^L \frac{d^2 \phi_i}{dx^2} \frac{d^2 \phi}{dx^2} dx$$

- Resolver la estructura con  $E$ ,  $I$ ,  $A$  constantes por el método de Rayleigh-Ritz

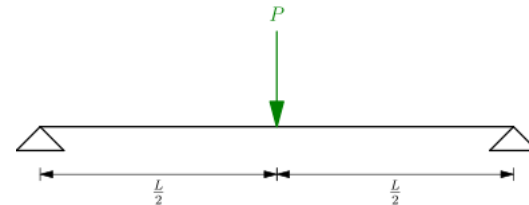

## Solución

La solución exacta es un polinomio de tercer grado, la aproximación del campo de desplazamientos será

$$v(x) = \begin{cases} \alpha_0 + \alpha_1 x + \alpha_2 x^2 + \alpha_3 x^3 & \text{para } 0 \leq x \leq \frac{L}{2} \\ \beta_0 + \beta_1 x + \beta_2 x^2 + \beta_3 x^3 & \text{para } \frac{L}{2} \leq x \leq L \end{cases}$$

Tramo  $0 \leq x \leq \frac{L}{2}$

Reemplazando  $v(0) = 0$  y  $v'(\frac{L}{2}) = 0$

$$\alpha_0 + \alpha_1(0) + \alpha_2(0)^2 + \alpha_3(0)^3 = 0$$

$$\alpha_1 + 2\alpha_2\left(\frac{L}{2}\right) + 3\alpha_3\left(\frac{L}{2}\right)^2 = 0$$

Resolviendo

$$\alpha_0 = 0$$

$$\alpha_1 = -\left(L\alpha_2 + \frac{3L^2}{4}\alpha_3\right)$$

Reemplazando en el campo de desplazamientos

$$v = -\left(L\alpha_2 + \frac{3L^2}{4}\alpha_3\right)x + \alpha_2 x^2 + \alpha_3 x^3$$

La curvatura es

$$\kappa = \frac{d^2 v}{dx^2} = 2\alpha_2 + 6\alpha_3 x$$

El funcional de energía es

$$\pi = \int_0^{\frac{L}{2}} \frac{EI}{2} \kappa^2 dx - \frac{P}{2} v\left(\frac{L}{2}\right)$$

Reemplazando

$$\begin{aligned} \pi = & \int_0^{\frac{L}{2}} \frac{EI}{2} (2\alpha_2 + 6\alpha_3 x)^2 dx \\ & - \frac{P}{2} \left[ -\left(L\alpha_2 + \frac{3L^2}{4}\alpha_3\right)\left(\frac{L}{2}\right) + \alpha_2\left(\frac{L}{2}\right)^2 + \alpha_3\left(\frac{L}{2}\right)^3 \right] \end{aligned}$$

Integrando

$$\pi = \frac{PL^2}{8}\alpha_2 + \frac{PL^3}{8}\alpha_3 + EIL\alpha_2^2 + \frac{3EIL^2}{2}\alpha_2\alpha_3 + \frac{3EIL^3}{4}\alpha_3^2$$

Minimizando el funcional

$$\frac{\partial \pi}{\partial \alpha_2} = 2EIL\alpha_2 + \frac{3}{2}EIL^2\alpha_3 + \frac{PL^2}{8} = 0$$

$$\frac{\partial \pi}{\partial \alpha_3} = \frac{3}{2}EIL^2\alpha_2 + \frac{3}{2}EIL^3\alpha_3 + \frac{PL^3}{8} = 0$$

Formando el sistema de ecuaciones

$$4EIL\alpha_2 + 3EIL^2\alpha_3 = -\frac{PL^2}{4}$$

$$EIL^2\alpha_2 + EIL^3\alpha_3 = -\frac{PL^3}{12}$$

Resolviendo

$$\alpha_2 = 0$$

$$\alpha_3 = -\frac{P}{12EI}$$

Reemplazando en  $v$

$$v(x) = \frac{PL^2}{16EI}x - \frac{P}{12EI}x^3$$

Factorizando

$$v(x) = \frac{P}{48EI}x(3L^2 - 4x^2)$$

Tramo  $\frac{L}{2} \leq x \leq L$

Reemplazando  $v(L) = 0$  y  $v'(\frac{L}{2}) = 0$

$$\beta_0 + \beta_1(L) + \beta_2(L)^2 + \beta_3(L)^3 = 0$$

$$\beta_1 + 2\beta_2\left(\frac{L}{2}\right) + 3\beta_3\left(\frac{L}{2}\right)^2 = 0$$

Resolviendo

$$\begin{aligned} \beta_0 &= -\frac{L^3}{4}\beta_3 & 4EIL\beta_2 + 9EIL^2\beta_3 &= -\frac{PL^2}{4} \\ \beta_1 &= -\left(L\beta_2 + \frac{3L^2}{4}\beta_3\right) & 9EIL^2\beta_2 + 21EIL^3\beta_3 &= -\frac{PL^3}{2} \end{aligned}$$

Reemplazando en el campo de desplazamientos

$$v = -\frac{L^3}{4}\beta_3 - \left(L\beta_2 + \frac{3L^2}{4}\beta_3\right)x + \beta_2x^2 + \beta_3x^3$$

La curvatura es

$$\kappa = \frac{d^2v}{dx^2} = 2\beta_2 + 6\beta_3x$$

El funcional de energía es

$$\pi = \int_{\frac{L}{2}}^L \frac{EI}{2} \kappa^2 dx - \frac{P}{2} v\left(\frac{L}{2}\right)$$

Reemplazando

$$\begin{aligned} \pi &= \int_{\frac{L}{2}}^L \frac{EI}{2} (2\beta_2 + 6\beta_3x)^2 dx \\ &\quad - \frac{P}{2} \left[ -\frac{L^3}{4}\beta_3 - \left(L\beta_2 + \frac{3L^2}{4}\beta_3\right)\left(\frac{L}{2}\right) + \beta_2\left(\frac{L}{2}\right)^2 + \beta_3\left(\frac{L}{2}\right)^3 \right] \end{aligned}$$

Integrando

$$\pi = \frac{PL^2}{8}\beta_2 + \frac{PL^3}{4}\beta_3 + EIL\beta_2^2 + \frac{9EIL^2}{2}\beta_2\beta_3 + \frac{21EIL^3}{4}\beta_3^2$$

Minimizando el funcional

$$\begin{aligned} \frac{\partial \pi}{\partial \beta_2} &= 2EIL\beta_2 + \frac{9}{2}EIL^2\beta_3 + \frac{PL^2}{8} = 0 \\ \frac{\partial \pi}{\partial \beta_3} &= \frac{9}{2}EIL^2\beta_2 + \frac{21}{2}EIL^3\beta_3 + \frac{PL^3}{4} = 0 \end{aligned}$$

Formando el sistema de ecuaciones

Resolviendo

$$\begin{aligned} \beta_2 &= -\frac{PL}{4EI} \\ \beta_3 &= \frac{P}{12EI} \end{aligned}$$

Reemplazando en  $v$

$$v(x) = -\frac{PL^3}{48EI} + \frac{3PL^2}{16EI}x - \frac{PL}{4EI}x^2 + \frac{P}{12EI}x^3$$

Factorizando

$$v(x) = \frac{P}{48EI} (L-x)(L^2 - 8Lx + 4x^2)$$

La solución completa será

$$v(x) = \begin{cases} \frac{P}{48EI} x(3L^2 - 4x^2) & \text{para } 0 \leq x \leq \frac{L}{2} \\ \frac{P}{48EI} (L-x)(L^2 - 8Lx + 4x^2) & \text{para } \frac{L}{2} \leq x \leq L \end{cases}$$

- Obtener la expresión de la matriz de rigidez de un elemento cualquiera mediante la energía potencial total

## Solución

Funcional de energía

$$\pi = \iiint_V \frac{1}{2} \varepsilon^T \sigma dV - \iiint_V u^T f_V dV - \iint_{\Omega} u^T f_{\Omega} d\Omega - \sum_{i=1}^n u_i^T P_i$$

Reemplazando la ley de Hooke generalizada y los campos de aproximación para desplazamientos y deformaciones unitarias

$$\begin{aligned}\pi &= \iiint_V \frac{1}{2} (B u_i)^T C (B u_i) dV - \iiint_V (N u_i)^T f_V dV \\ &\quad - \iint_{\Omega} (N u_i)^T f_{\Omega} d\Omega - \sum_{i=1}^n u_i^T P_i\end{aligned}$$

Reordenando términos

$$\begin{aligned}\pi &= \iiint_V \frac{1}{2} u_i^T B^T C B u_i dV - \iiint_V u_i^T N^T f_V dV \\ &\quad - \iint_{\Omega} u_i^T N^T f_{\Omega} d\Omega - \sum_{i=1}^n u_i^T P_i\end{aligned}$$

Las constantes salen del integrando

$$\begin{aligned}\pi &= \frac{1}{2} u_i^T \iiint_V B^T C B dV u_i - u_i^T \iiint_V N^T f_V dV \\ &\quad - u_i^T \iint_{\Omega} N^T f_{\Omega} d\Omega - u_i^T \sum_{i=1}^n P_i\end{aligned}$$

Minimizando el funcional

$$\frac{\partial \pi}{\partial u_i} = \iiint_V B^T C B dV u_i - \iiint_V N^T f_V dV - \iint_{\Omega} N^T f_{\Omega} d\Omega - \sum_{i=1}^n P_i = 0$$

Reordenando

$$\iiint_V B^T C B dV u_i = \iiint_V N^T f_V dV + \iint_{\Omega} N^T f_{\Omega} d\Omega + \sum_{i=1}^n P_i$$

La matriz de rigidez es

$$K = \iiint_V B^T C B dV$$